

**MICRO CONTROLLER / DSC BASED Gen-Next SMART HYBRID UPS** are based on Hybrid Technology which is a Perfect Combination of Digital and Sinewave Technologies for Better Performance and High Reliability. The Hybrid Technology used ensures Noiseless Performance, Quick Charging, More Load, Longer Battery Life & Longer Backups.

- ♦ Digital Signal Controller (DSC) Based Intelligent Control Hybrid Design.
- ♦ PWM Controlled multistage ATM (Automatic Trickle Mode) Charging.
- ♦ Display Indications (Status & Fault).
- ♦ Smart Overload Sense and Short Circuit Protection.
- ♦ Easily Serviceable and Auto Reset Feature.
- ♦ In-built Bypass Switch.
- ♦ Slide switch to select float charging voltage.
- ♦ Mains Input Voltage Range Selection.
- ♦ Quick Charging option.

**Over Voltage Protection:** The UPS will switch to UPS mode & offers power from the battery when the mains voltage is too high.

**Over Load / Short Circuit Protection :** If the UPS is excessively overloaded in UPS mode or encounters a short circuit, it will go into protection mode. The output will be shut down in this case.

**Battery Deep Discharge / Over Charge Protection :** The UPS has in-built electronic protection circuit which protects the batteries from getting deep discharged or over charged.

## TECHNICAL SPECIFICATIONS

<b>Product</b>	<b>SMART HYBRID 1875 24V</b>
<b>VA/Wattage</b>	1650VA / 1320W

Input voltage (Standard Range)	100V-300V
(Narrow range)	180V-260V
Output Voltage on mains mode	Same as input
Output Voltage on UPS mode	210V ± 10%
Output frequency on UPS mode	50 Hz ± 0.1 Hz
Switching from mains to UPS and from UPS to mains	Automatic
Output waveform on mains mode	Same as Input
Output waveform on UPS mode	PURE SINEWAVE
Battery charging current	Constant charging approx 10% of the rated battery current in AH
Charger	Power Factor Controlled Boost Technology
Efficiency	> 80%
UPS Overload/UPS Short Circuit	110% / 300%
UPS Transfer Time	≤ 15msec.
Browns out mains voltage	100V ± 40V
Technology	Micro Computer Based Intelligent Control Design.
Auto Reset Feature	Yes
Operating Temperature	0-45°C

**NOTE:** \*Power Factor may vary depending upon the Load. \*Because of a policy of continuous product improvement, specifications are subject to change without notice.

## FRONT PANEL

### I. LED Indications

- Mains ON.
- UPS on Backup.
  - ★ LED Continuously Glows when Charged.
  - ★ LED Blinks when Battery is Charging.
- Battery Charging.
  - ★ LED Blinks with Beep, if UPS is Overloaded.
  - ★ LED Continuously Glows with Beep and No Output, if Short Circuit.
- UPS Overload.
- Battery Low.
- Circuit Breaker Trip.

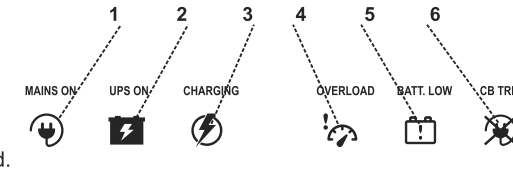

## TROUBLE SHOOTING

Problem	Possible Cause / Action Suggested
1. <b>Main Supply is Normal but:-</b>	
a) UPS is working on battery ( <b>UPS ON Green LED Glows</b> )	a) Dead wall socket. Line AC input connections are loose / not proper.
b) CB Trip ( <b>CB Trip Red LED Glows and Buzzer continuously sounds</b> ) or No output from UPS	b) Check Circuit Breaker at the Rear. Push the Circuit Breaker (Reset) to Switch On the output. If trips again, call electrician to check shorting/overload in the output circuit.
2. <b>UPS trips frequently at UPS mode.</b>	The load is more. Reduce the load and reset the UPS.
3. <b>UPS Mode but no power:-</b>	
a) Overload ( <b>Overload Red LED Glows</b> )	a) Reduce the load and reset the switch on the front panel( OFF-ON).
b) Low Battery ( <b>Low Battery Red LED Glows</b> )	b) Battery has discharged. Recharge the battery after the mains restoration.
c) Short Circuit ( <b>Overload Red LED Glows</b> )	c) Check the wiring, reduce the load & turn the reset switch on the front panel ON-OFF-ON.
4. Backup Time is Less.	a) Check battery water and charge the batt. with mains minimum for 8-12 hours. If still less backup, get the batt. checked up from authorised service personnel.
5. UPS does not operate.	a) Check the battery and the mains connections. b) Internal problem. Bypass UPS as explained in next section and call auth. service personnel.

## BATTERY - INSTALLATION & CONNECTIONS

**CAUTION:** Battery Polarity must be checked before connections. Wrong Polarity connection with UPS will cause Reverse Protection Fuse Blown and may lead to Fire Hazards.

Installation shall be done by a knowledgeable person.

- Take precautions while connecting the thimble of battery cable to the battery post, avoid short circuit by spanner etc.

### BATTERY CONNECTIONS:

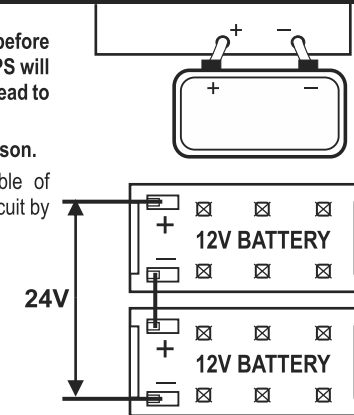

**NOTE:** Recommended Battery(Lead Acid Type) 2x12V: 100AH to 200AH.

## CONNECTION DIAGRAM FOR INSTALLATION

TO BE DONE BY A COMPETENT & KNOWLEDGEABLE PERSON.

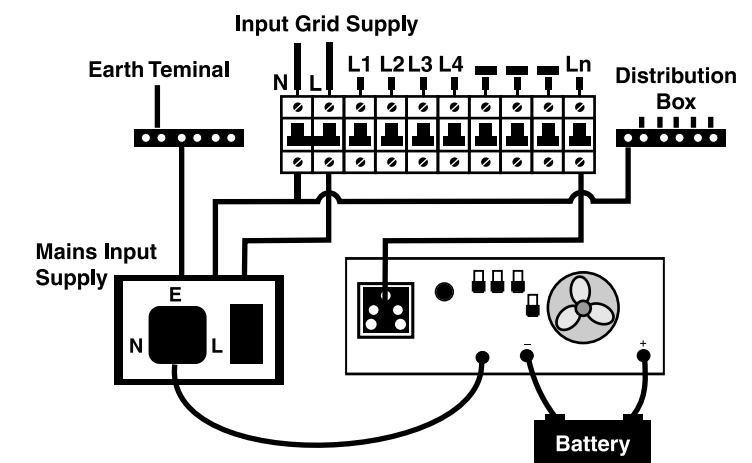

L - Mains Line l/p  
N - Neutral  
E - Earth

\* When the Push switch is at OFF position then it By-Pass the mains AC supply & charges the Battery.

\* When the Push switch is at ON position(Pressed) and is having alternating supply, It charges the battery and has mains By-Pass and when the alternating supply(mains) is not present at that instant it is ready for Backup.

## STEPS FOR UPS INSTALLATION

TO BE DONE BY A COMPETENT & KNOWLEDGEABLE PERSON.

- Switch OFF the supply to the distribution point to which the UPS unit is to be connected.
- For extra safety also remove the fuses from the line. Make absolutely sure with measurement that there is no power.
- A readily accessible disconnect device must be incorporated in all fixed input wiring. The disconnect device shall have a contact separation of at least 3mm. The UPS has automatic backfeed isolation but for extra safety a warning label can be added on all primary power isolators installed remote from the UPS to warn electrical maintenance personnel.
- Check the building wiring. Improper wiring will not prevent the UPS from operating but will limit its protection capability. Improper building wiring could result in equipment damage that is not covered in warranty.
- Connect the Battery/Batteries to UPS as per its requirement.
- Keep the front switch of UPS on OFF position.
- Connect the Load wire to the right hole of Output Socket located on the rear panel of UPS.
- Switch ON the front Switch of the UPS.
- Connect AC input wire to commercial mains socket.

## SERVICING / WARRANTY

Microtek International P. Ltd., warrants each instrument to be free from defects in materials and workmanship for a period of Two years after initial delivery. This obligation is limited to servicing any instrument or part returned to the authorised service center for that purpose and to making good any parts thereof which shall, within the warranty period, be returned to the company or authorised Service center under a written intimation and which to the company's satisfaction be found defective. The company reserves the right to decide as to whether the repair work should be carried out in the company's service center or at site or at any other place.

The freight incurred for to and fro dispatch will have to be borne by the customer and the transit risk for the material will rest with the customer.

The warranty will be invalidated if defects arising in company's opinion are by reasons of accident, abuse, misuse, neglect, Improper Installation (If not undertaken by the company or its representative), fire, flood, any other act of God and any other natural calamities. Further, this warranty does not extend to any instrument which has been repaired / tampered with by any agency/person not authorized by the company. The services given for the same will be paid service.

The warranty will last for a period of 24 months from the date of initial delivery/dispatch of the instrument if used within its specifications. The warranty for the replaced components will lapse along with that of the main instrument.

MICROTEK International P. Ltd., reserves the right to make changes in design and specifications without notice and without any obligation to install such changes on units previously supplied.

In no event will MICROTEK International P. Ltd., its distributors / dealers be liable for any loss or injury or damage caused to life or property or death & disability caused to any form of life for any reasons whatsoever. The company, its distributors / dealers will also not be liable for consequential damages or for any expenses incurred by the buyer or user, due to use or sale of products sold by MICROTEK International P. Ltd., directly or through its authorised Distributors / dealers or any third party.

## SAFETY INSTRUCTIONS

Always connect the UPS to a two pole, three-wire grounding mains socket, near by the product. The socket must be connected to appropriate branch protection (fuse/circuit-breaker). Connection to any other type of socket may result in a shock hazard.

To switch off the UPS output in emergency, use switch on the Front panel. Also disconnect the mains cord and battery wires.

Avoid installing the UPS in open, excessively humid place or where there is water or near flammable materials (plywood, chemicals, gasoline etc.). Care must be taken to ensure that the UPS is kept away from heat-emitting appliances such as a heater, blower, oven etc.

The unit must also be placed in a manner that it avoids exposure to sunlight. The place of installation should be well-ventilated & easily accessible for servicing. Ensure that ELCB/RCCB is not connected at either Input or Output. Only MCB upto 63A or MCCB above 100A to be used as per UPS capacity. Foreign objects and water must not enter the UPS. Always ensure that objects containing liquid are avoided near the unit.

Place the Battery Compartment as near as possible to the UPS. Don't allow sparks near the Battery. Be sure not to come in contact with Battery Acid by any means.

Always Switch Off the UPS and disconnect mains when disconnecting the Battery. Avoid connecting the stabilizer between Utility Power and UPS. The AVR of the stabilizer may cause rebooting of the Computer. The equipment must be earthed.

Do not open the UPS there are dangerous high voltages inside even when the power is OFF, Contact the Company only if it is not working properly.

Replace Batteries and the Fuse only with same Rating and Type.

Do not place UPS on a sloping shelf unless properly secured. Use perfect stand to hold the UPS.

Backfeed, See the warning label on the UPS.

## IMPORTANT

In the event of any instrument requiring service at our authorised service centre, the following procedure should be adopted:-

1. The instrument must be securely packed, preferably in its original packing. Also ensure that nothing inside packing is damaged. Please transport the product in its original packing to protect against shock, damage & impact.
2. We reserve the right to charge the consignee for any damage incurred during transit.
3. The output of the UPS should never be connected to a generator or incoming utility power source. This situation is far worse than a short-circuit. If the unit survives the condition, it will shutdown until correction is made.

## GOING ON VACATIONS

1. Must put the UPS ON/OFF Switch in OFF Position.

## DO'S & DON'TS RELATED TO UPS

### Do's Related to UPS

- ✓ Unplug and Switch OFF the UPS before touching or cleaning the surface.
- ✓ Unplug the UPS from the wall outlet during a Lightening Storm.

### Don'ts Related to UPS

- ✗ Don't block the bottom ventilation slots by cloth or other material it may result in fire hazard.
- ✗ Don't place the UPS near radiation or heat source.
- ✗ Don't Install near Kitchen Sink, Laundry, Wash Bowl, Bath Tub or Swimming Pool.

In case of any Service requirement kindly contact Microtek Customer Care, specifying following details:

- Model Number & Serial Number of the Product.
- Name & phone no. of the contact person with full address & e-mail ID if any.
- Reported problem/description of the complaint.

**Note:** (a) Refer all servicing queries to Microtek Customer Care only.  
(b) Please take care that Serial Number is kept intact and that the product is not allowed to be fiddled (opened) by any unauthorised person; otherwise the warranty will be void.

### MICROTEK CUSTOMER CARE:

ALL INDIA: 7283838383  
WHATSAPP: 08800255733 E-mail: cc@microtek.in

\*All disputes subject to Delhi jurisdiction only.

**MICROTEK INTERNATIONAL P. LTD.**  
H-57, Udyog Nagar, Rohtak Road, New Delhi-110041.

## POST WARRANTY ANNUAL MAINTENANCE CONTRACT (AMC)

Microtek Offers Annual Maintenance Contract to save you from any inconvenience in case of a product failure post warranty. Various options are available in select cities for all models of Microtek Products:-

**For Details, Contact nearest Microtek Branch or e-mail at: ho@microtek.in**

## INSTRUMENT DESCRIPTION

### MICROTEK SMART HYBRID EXTERNAL BATTERY UPS

### DOUBLE BATTERY (24V) System

SMART HYBRID 1875 24V  
(MTKDV1K875S)

SERIAL NO.
------------

Authorised Dealer Stamp with Signatures

Vend. C:  
Form No.: OPN/003-356  
Issue No.: 02, 25/04/2024 (Part Code: 902-891-1875) 002-390-SMART HYBRID 1875 V.2



**Smart Hybrid**  
PERFECT COMBINATION OF DIGITAL + SINEWAVE TECHNOLOGY

**SMART HYBRID 1875 24V**



## USER MANUAL



www.microtek.in